

Part No. 99-0024:A

RL 50A

Hydropneumatic tool for installation of rivet nuts and rivet studs from M3 to M12 with "autospin" automatic spin-on feature

Scope of use:

Rivet nuts	M3	M4	M5	M6	M8	M10	M12
Aluminium, Brass	✓	✓*	✓*	✓*	✓*	✓	✓
Steel	✓	✓*	✓*	✓*	✓*	✓	
Stainless	✓	✓*	✓*	✓*	✓*	✓	

Mandrels & anvils included

	✓	✓	✓	✓	✓	
--	---	---	---	---	---	--

* including pulling bolts

Technical parameters:

Model	RL 50A
Pulling Force	23.5 kN / 6 bar
Working stroke	2.5–6.5 mm
Weight	2.2 kg
Force / Weight Ratio	10.68 kN/kg
Length	292 mm
Height	255 mm
Air Consumption	4.6 litres / rivet
Working Air Pressure	5–7 bar
Hose connection	Ø 6 mm (G 1/4")



Description:

- autospin feature - push the mandrel to spin-on the fastener
- high output at small dimensions
- exact smooth stroke adjustment
- one trigger control
- button for manual spin-off
- fastener spins off automatically
- simple operation
- low noise
- low maintenance
- ergonomic handle is comfortable to hold
- low transferred vibrations
- rotating air joint connection
- air intake can be moved to suit either left or right handed operator
- balancer hook
- safety over-pressure dump valve
- reliability verified in practice
- non slip base
- base cover prevents damage to workpiece



Dimensions of tool:

RL 50A

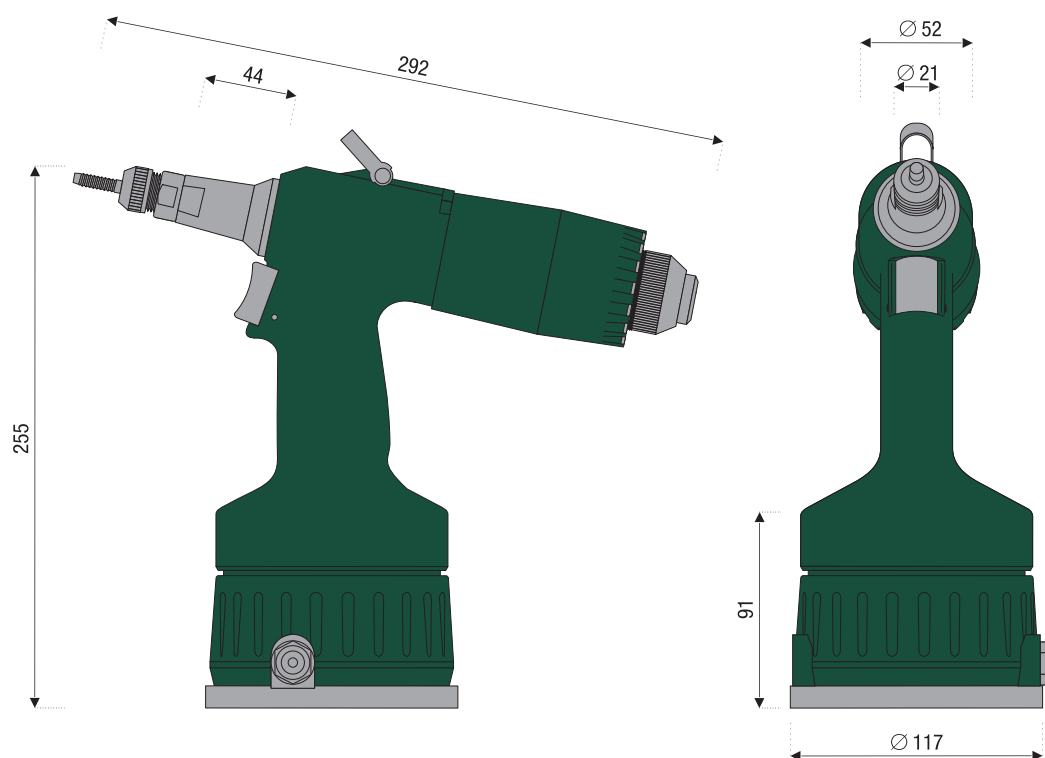



Standard accessories:

Description	Part No.
Air Joint Assembly	87-0281
Oil Refill Set	87-0187

Optional accessories:

Description	Part No.
Hydraulic Oil for Tool - 1 Litre	87-0188
Front Stroke Adjustment	87-0497

Anvils, mandrels and pulling bolts:

RL 50A			
M3	87-0026	87-0039	
M4	87-0027	87-0040	87-0046
M5	87-0028	87-0041	87-0047
M6	87-0029	87-0042	87-0048
M8	87-0030	87-0043	87-0049
M10	87-0031	87-0044	
M12	87-0032	87-0045	